

## Reliability of Uninterruptible Power Supplies

### Abstract

Reliability is one of the mayor points for the configuration and the final decision for the right UPS system. The paper shows some calulations and figures of various UPS configurations and gives advice how to handle this issue. Further more the “Mean Time Between Failures” (MTBF) and the “Mean Time To Repair” (MTTR) are discussed and described.

### Index

Introduction	2
1. Single UPS without static bypass switch (SBS)	2
2. Single UPS WITH static bypass switch (SBS)	4
3. Parallel Redundant UPSS WITH Static Bypass Switch (SBS)	6
Conclusion	11

## Introduction

The primary objective in the implementation of a UPS system is to improve the reliability to the limits of technical capability, the ultimate aim being to totally eliminate the possibility of any disturbance or downtime. In the 50's when the first static UPS systems appeared they were composed of a rectifier, battery and inverter and were used to stabilize the output power and to continue to supply the load for a short period of time (autonomy of battery) in the event of a rectifier failure. The reliability of this simple UPS chain depends dominantly on the inverter reliability. An inverter failure meant an immediate load crash. Furthermore, the downtime (no supply to the load) would last as long as the inverter repair. In the early 60's the static bypass switch was introduced to enable an interruption-free load transfer to the stand-by mains in the event of inverter failures or overloads. The stand-by mains although far not as reliable as the UPS, serves as a reserve power supply in case of an inverter failure to enable the continuation of the power supply to the load while the inverter is being repaired. This new architecture had substantially improved the overall reliability which did not depend dominantly on the inverter reliability anymore. The reliability of the new UPS with static bypass depended on the quality of the mains ( $MTBF_{MAINS}$ ), the time to repair of the UPS ( $MTTR_{UPS}$ ) and on the reliability of the static switch. Further on in this paper (page 4) the impact of both the ( $MTBF_{MAINS}$ ) and ( $MTTR_{UPS}$ ) on the overall UPS reliability are shown.

The everyday activities which are dependent upon computer controlled real time information systems have grown exponentially in recent years and the requirements for highest reliability UPS configurations have become every day practice. Very critical loads cannot rely on a power supply configuration of a single UPS with static bypass system; the need for (n+1) redundant parallel UPS configurations is becoming a standard.

In this paper the reliability of the various UPS configurations is shown. The reliability figures of the rectifier/booster, battery, inverter, static bypass and other parts are based on the reliability figures presented in the MIL-HDBK-217 F (Not.2, 1995). The following calculations were implemented on the NEWAVE CONCEPTPOWER UPS-Series and they have been confirmed by field statistics which unfortunately due to NEWAVE'S policy cannot be disclosed.

### 1. Single UPS without static bypass switch (SBS)

The reliability of a single UPS without bypass depends basically on the reliability of the rectifier, battery and inverter (see electrical block-diagram in Fig.1).

Example: In the event of an inverter fault the load would crash.

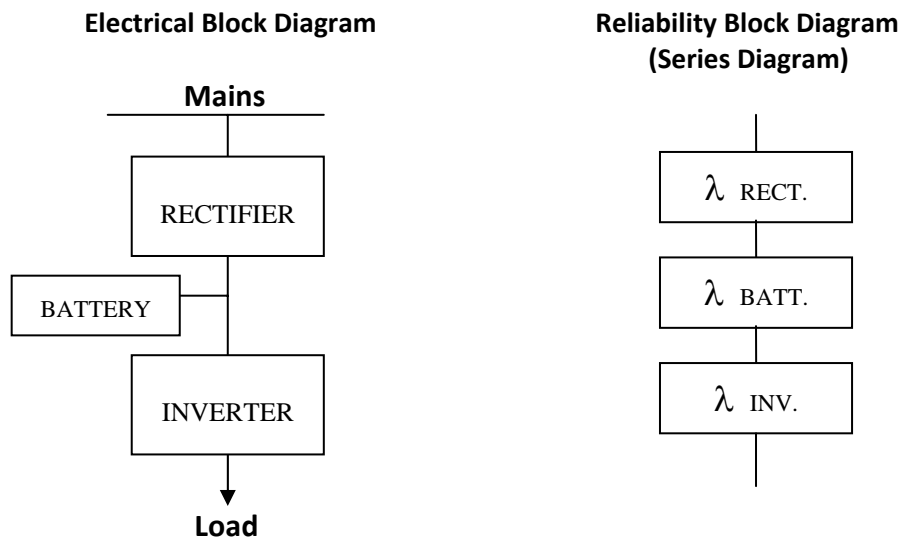

Fig. 1 Single UPS without static bypass. Electrical block diagram and reliability diagram

Description of the variables that are used in the equations:

MTBF<sub>SU</sub>: Mean Time Between Failures of Single Unit without static bypass

$\lambda_{UPS}$  Failure Rate of Single Unit without static bypass switch

$\lambda_{RECT}$  Failure Rate Rectifier

$\lambda_{BATT}$  Failure Rate Battery

$\lambda_{INV}$  Failure Rate Inverter

Calculation of MTBF for UPS System WITHOUT bypass (MTBF<sub>SU</sub>):

$$MTBF_{UPS} = 1 / \lambda_{UPS}$$

$$\lambda_{UPS} = \lambda_{RECT.} + \lambda_{BATT.} + \lambda_{INV.} \dots\dots\dots (E.1)$$

If the figures from NEWAVE'S statistical failure-analysis  $\lambda_{RECT} = 20 \cdot 10^{-6} [h^{-1}]$ ,  $\lambda_{BATT} = 10 \cdot 10^{-6} [h^{-1}]$ ,  $\lambda_{INV.} = 20 \cdot 10^{-6} [h^{-1}]$  are applied in equation (E.1) the Mean Time Between Failure (MTBF<sub>UPS</sub>) for a UPS system without static bypass switch will be:

$$\boxed{MTBF_{UPS} = 20'000 [h]}$$

**2. Single UPS WITH static bypass switch (SBS)**

The reliability of a single UPS can be increased significantly by introducing a redundant mains power source by and linking it to main UPS supply source by means of a static bypass static transfer switch.

Example: In the event of an inverter fault the load WILL NOT crash. The load will be transferred to mains interruption-free.

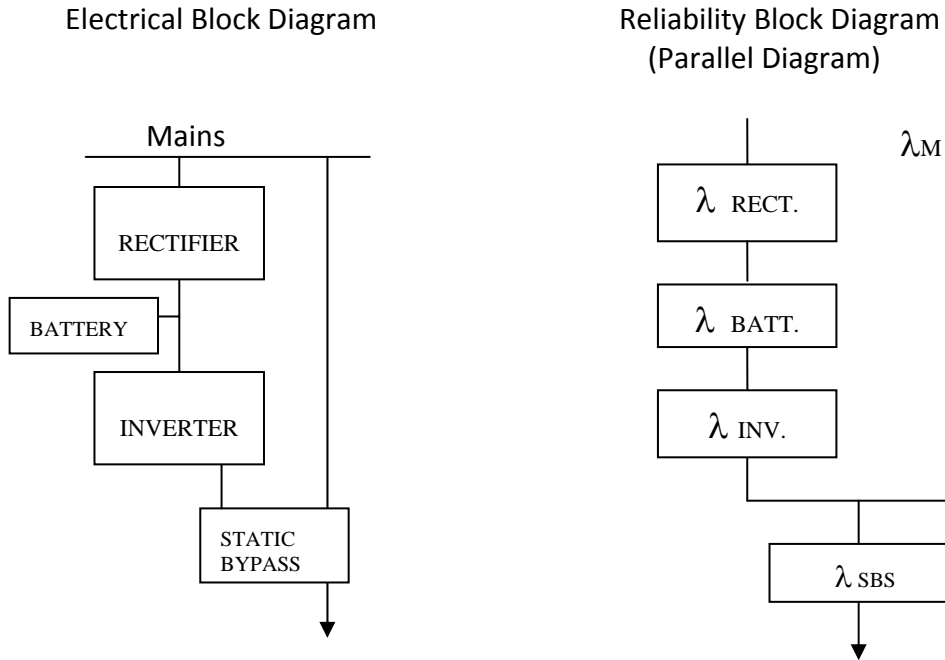

Fig. 2 Single UPS WITH static bypass. Electrical block diagram and reliability diagram

Description of the variables that are used in the equations:

- MTBF<sub>UPS+SBS</sub>: Mean Time Between Failures of Single Unit WITH static bypass switch (SBS)
- MTBF<sub>M</sub>: Mean Time Between Failures of MAINS
- $\lambda_{UPS+SBS}$ : Failure Rate of Single Unit WITH static bypass switch
- $\lambda_{SBS}$ : Failure Rate of Static Bypass Switch with control circuit
- $\lambda_{PBUS}$ : Failure Rate of Parallel Bus (only for parallel systems)
- $\lambda_M$ : Failure Rate of MAINS
- $\mu_{SU}$ : Repair Rate of Static Bypass Switch ( $\mu_{SU} = 1 / MTTR_{UPS}$ )
- $\mu_M$ : Repair Rate of MAINS ( $\mu_M = 1 / MTTR_M$ )
- MTTR<sub>SBS</sub>: Mean Time To Repair of Static Bypass Switch
- MTTR<sub>M</sub>: Mean Time To Repair of MAINS

Please note that all calculations are performed by using the following constants:

- MTBF<sub>M</sub> = 50 [h], this figure represents a “good quality” mains.
- MTTR<sub>UPS</sub> = 6 [h]
- MTTR<sub>M</sub> = 0.1 [h]

Furthermore from NEWAVE’S statistical failure-analysis we have the following figures for the failure rates of the static bypass switch for the power part and the control electronic part:

$$\lambda_{SBS} = 2 \cdot 10^{-6} [h^{-1}]$$

Calculation of MTBF for UPS System WITH static bypass switch (MTBF<sub>SU+SBS</sub>):

$$MTBF_{UPS+SBS} = 1 / \lambda_{UPS+SBS}$$

$$\lambda_{UPS+SBS} = \lambda_{UPS} // \lambda_M + \lambda_{SBS} \dots\dots\dots (E.2)$$

$$\lambda_{UPS} // \lambda_M = \frac{\lambda_{UPS} \lambda_M (\lambda_{UPS} + \lambda_M + \mu_{UPS} + \mu_M)}{\lambda_{UPS} \lambda_M + \mu_{UPS} \mu_M + (\lambda_{UPS} + \lambda_M) (\mu_{UPS} + \mu_M) + \lambda^2_{UPS} + \lambda^2_M} = \frac{\lambda_{UPS} \lambda_M (\mu_{UPS} + \mu_M)}{\mu_{UPS} \mu_M} = 6 \cdot 10^{-6} [h^{-1}]$$

$$\lambda_{UPS+SBS} = \lambda_{UPS} // \lambda_M + \lambda_{SBS} = 6 \cdot 10^{-6} [h^{-1}] + 2 \cdot 10^{-6} [h^{-1}] = \underline{8 \cdot 10^{-6} [h^{-1}]}$$

$$MTBF_{UPS+SBS} = 125'000h$$

NOTE: In the above formula it can be seen that the reliability of the UPS with static bypass switch (MTBF<sub>UPS+SBS</sub>) depends largely on three parameters: reliability of the mains, the MTTR of the UPS and the reliability of the static bypass switch. This dependence is illustrated in Fig 3.

MTTR = 6h  
 MTBF<sub>M</sub> = 50h

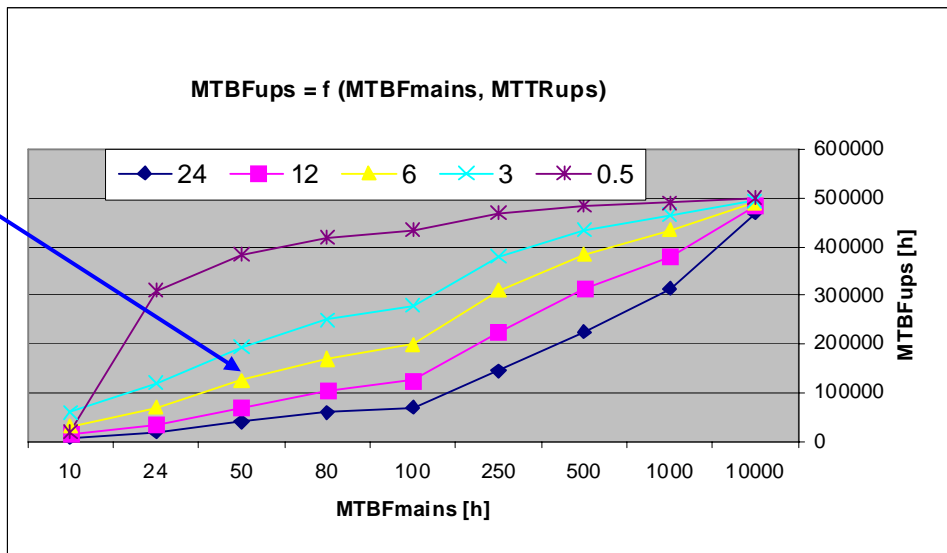
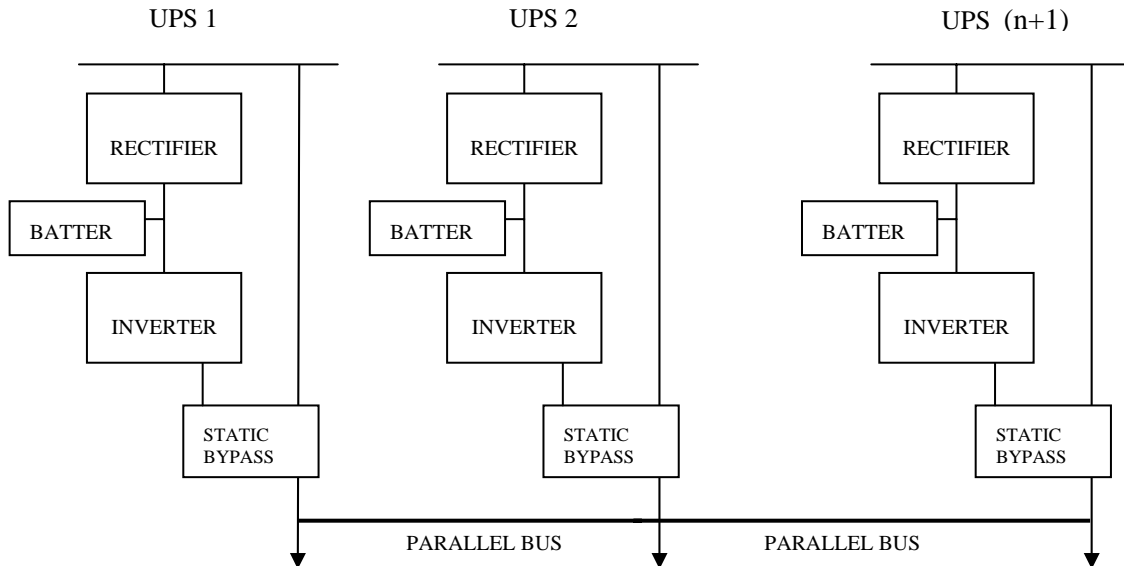

Fig. 3 This graph shows the dependence of the MTBF<sub>UPS+SBS</sub> on MTBF<sub>MAINS</sub> and MTTR<sub>UPS</sub>.

### 3. Parallel Redundant UPSs WITH Static Bypass Switch (SBS)

The reliability of a single UPS can be increased significantly by introducing a redundant parallel configurations.



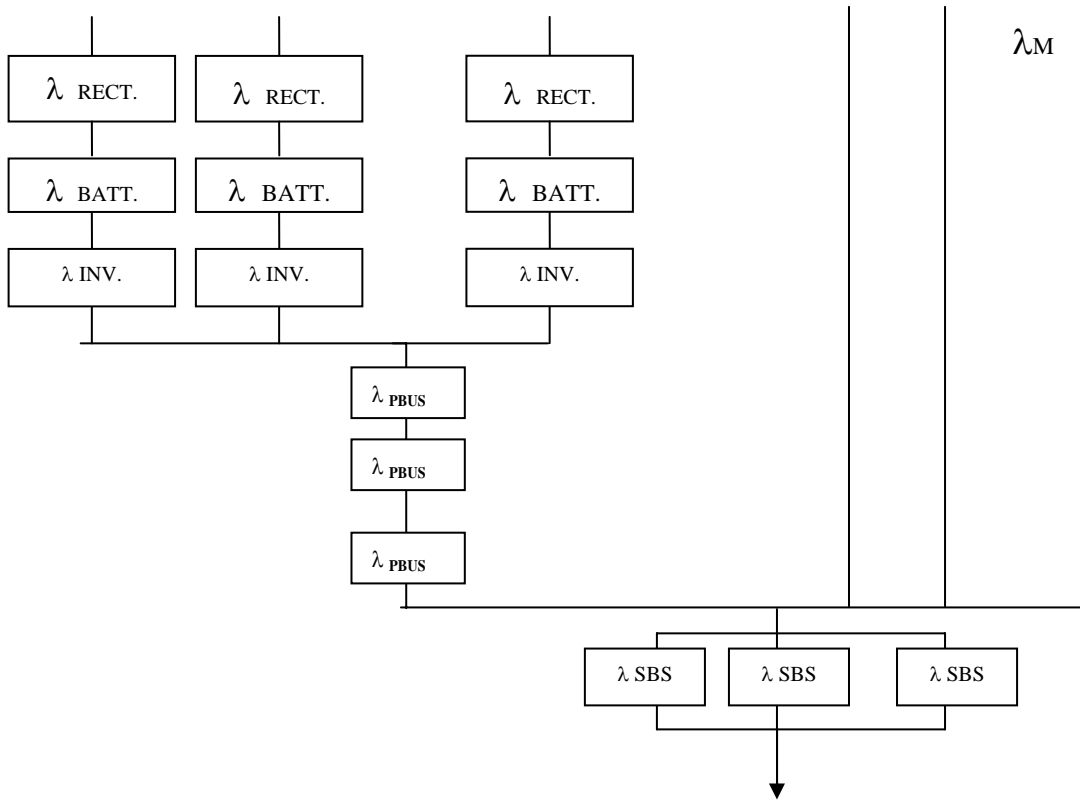

Fig. 4 Electrical and Reliability Block Diagram of (n+1) Parallel Redundant UPS Configuration.

Calculation of MTBF for a (n+1) REDUNDANT PARALLEL UPS System (MTBF(n+1) UPS+SBS):

We will start by the equations used for the calculation of the failure rate:

$$\lambda (n+1)_{UPS+SBS} = (\lambda_{UPS1} // \lambda_{UPS2} \dots // \lambda_{UPS(n+1)}) + (n+1) \lambda_{UPBUS} + (\lambda_{SBS1} // \lambda_{SBS2} \dots // \lambda_{SBS(n+1)}) \dots (E.3)$$

Failure Rate:  $\lambda (n+1)_{UPS+SBS} \sim (n+1) \lambda_{PBUS} \dots (E.4)$

Reliability:  $MTBF(n+1)_{UPS+SBS} = 1 / \lambda (n+1)_{UPS+SBS} \dots (E.5)$

Availability:  $A (n+1)_{UPS+SBS} = MTBF(n+1)_{UPS+SBS} / (MTBF(n+1)_{UPS+SBS} + MTTR_{UPS}) \dots (E.6)$

The reliability of a (n+1) parallel redundant system depends largely on the reliability of the failure rate of the PARALLEL BUS which is the only single point failure.

The UPS parallel redundant chains, the static bypass switches and their control electronics as well as the mains power lines are all redundant and have therefore minor or even neglecting impact on the overall reliability.

We will perform some calculations for parallel redundant systems, by using the following constants:

MTBFM = 50 [h], this figure represents a “good quality” mains.

$\lambda_{PBUS} = 0.4 \cdot 10^{-6} [h^{-1}]$

Redundant Parallel Configuration	Reliability (MTBF)	Failure Rate ( $\lambda$ )
(1+1) redundant configuration	1'250'000 [h]	$\sim 0.8 \cdot 10^{-6} [h^{-1}]$
(2+1) redundant configuration	830'000 [h]	$\sim 1.2 \cdot 10^{-6} [h^{-1}]$
(3+1) redundant configuration	625'000 [h]	$\sim 1.6 \cdot 10^{-6} [h^{-1}]$
(4+1) redundant configuration	500'000 [h]	$\sim 2.0 \cdot 10^{-6} [h^{-1}]$
(5+1) redundant configuration	420'000 [h]	$\sim 2.4 \cdot 10^{-6} [h^{-1}]$

**Table 1** MTBF and Failure Rate of (n+1)-Redundant Configurations, N=1,2,3,4 and 5

Conclusion:

In the single UPS chain (rectifier, battery and inverter) the reliability of the UPS largely depends on the reliability of the inverter.

By introducing the static bypass switch i.e. a reserve mains power supply, the reliability will increase by a factor of 6 if the mains MTBF is 50h (good quality) and the MTTR of UPS is 6h. This reliability level is unfortunately not sufficient, because it still depends substantially on the reliability of the raw mains and on the quality of the after sales organization (reaction time, traveling time, repair time etc.)

Modern critical loads have far higher reliability requirements and cannot rely on the mains quality and on longer repair times.

To overcome the dependability from the raw mains, (n+1)-redundant parallel UPS-configurations are suggested. The disadvantage of traditional stand-alone (n+1)-redundant configuration is the relatively long repair time of the UPS (typically 6–12h). By implementing modular, hot-swappable, (n+1) redundant parallel systems the critical load will be completely mains-independent; a faulty UPS-module may be replaced without the need to transfer the rest of the UPS modules to raw mains (hot-swap). Furthermore the replacement of the modules takes at most 0.5h, which dramatically decreases the time to repair in comparison to traditional parallel systems.



Below you will find an example where various UPS configurations are compared and it is shown what impact the choice of the right system/configuration might have on the reliability and availability:

Example:

**Comparison of the Availability of a Traditional (1+1)-Redundant UPS Configuration and a Modular (4+1)-Redundant UPS Configuration**

Fig. 5 shows a block diagram of two redundant UPS configurations. The system on the left represents a (1+1)-redundant configuration with traditional stand-alone UPSs, whereas the system on the right side represents a (4+1)-redundant configuration with modular hot swappable-modular UPSs.

**(1+1)-Redundant Configuration  
(traditional stand-alone)**

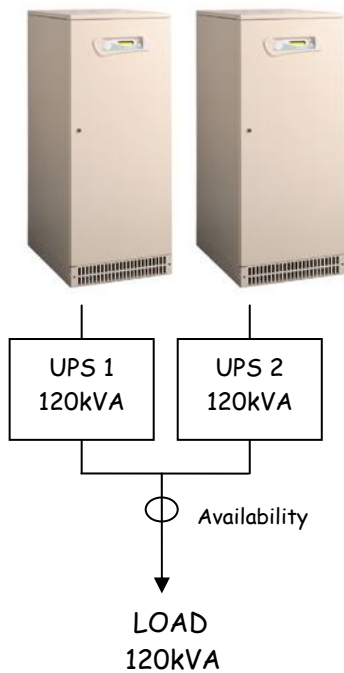

**(4+1)-Redundant Configuration  
(modular, hot-swappable)**

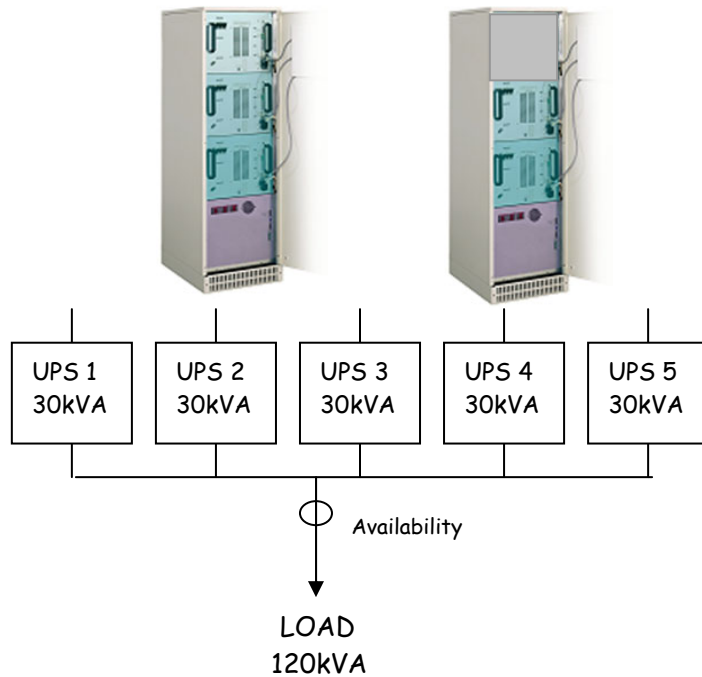

Fig. 5 Block diagram of two redundant UPS configurations

AVAILABILITY (A) is an important parameter when evaluating the reliability of UPS-configurations. A is defined as follows:

$$A = \frac{MTBF_{UPS}}{MTBF_{UPS} + MTTR_{UPS}} \dots \dots \dots (E.7)$$

From equation (E.7) we see that the Availability of a UPS depends on the:

$MTBF_{UPS}$  = Mean Time Between Failures of a UPS configuration and  
 $MTTR_{UPS}$  = Mean Time To Repair of the UPS.

Table 2 shows the Availability Comparison of the UPS configurations in Fig.5. Note that the  $MTBF_{UPS}$  figures for the UPS configurations are taken from Table 1.

Two cases are considered:

Case 1:

both UPS-configurations have the same Meant Time To Repair:  
 $MTTR_{UPS} = 6$  [h]

Case 2:

The traditional stand-alone UPS configurations has:  
 $MTTR_{UPS} = 6$  [h], whereas  
 Modular UPS configuration with hot-swappable modules has:  
 $MTTR_{UPS} = 0.5$  [h]

	<b>Redundant-Configuration (1+1)</b>	<b>Redundant-Configuration (4+1)</b>
Case 1		
MTBF	1'250'000 [h]	500'000 [h]
MTTR	6 [h]	6 [h]
Availability	0,9999952 (5 nines)	0,9999888 (4 nines)
Case 2		
MTBF	1'250'000 [h]	500'000 [h]
MTTR	6 [h]	0.5 [h]
Availability	0,9999952 (5 nines)	0,9999990 (6 nines)

Comments:

Case 1: The Availability of (1+1)-Redundant Configuration is higher than the Availability (4+1)-Redundant Configuration if the MTTR is the same for both configurations.

This evident due to the fact that the MTBF of a (1+1)-Redundant Configuration is higher than the MTBF of a (4+1)-Redundant-Configuration

Case 2: The Availability of a (1+1)-Redundant-Configuration with longer MTTR may be lower tan the Availability of a (4+1)-Redundant-Configuration with a shorter MTTR.

## Conclusion

From the above cases it is shown how important the parameter MTTR is for achieving high availabilities. If in one unit the above redundant configurations of the UPS is faulty, there will be no redundancy left (low-availability regime) and we need to repair/replace the faulty part/module as quick as possible, in order to restore the redundancy (high-availability-regime).

With Conceptpower modular UPS you can reach shortest MTTR's and consequently highest availabilities even if we parallel higher number of modules.

---

[1] A. *BIROLINI* "Reliability Engineering, Theory and Practice"